

Title		
MIDID TO CV CONVERTER		
Size	Document Number	Rev
A	500-1017	A
Date:	Thursday, July 03, 2014	Sheet 1 of 8

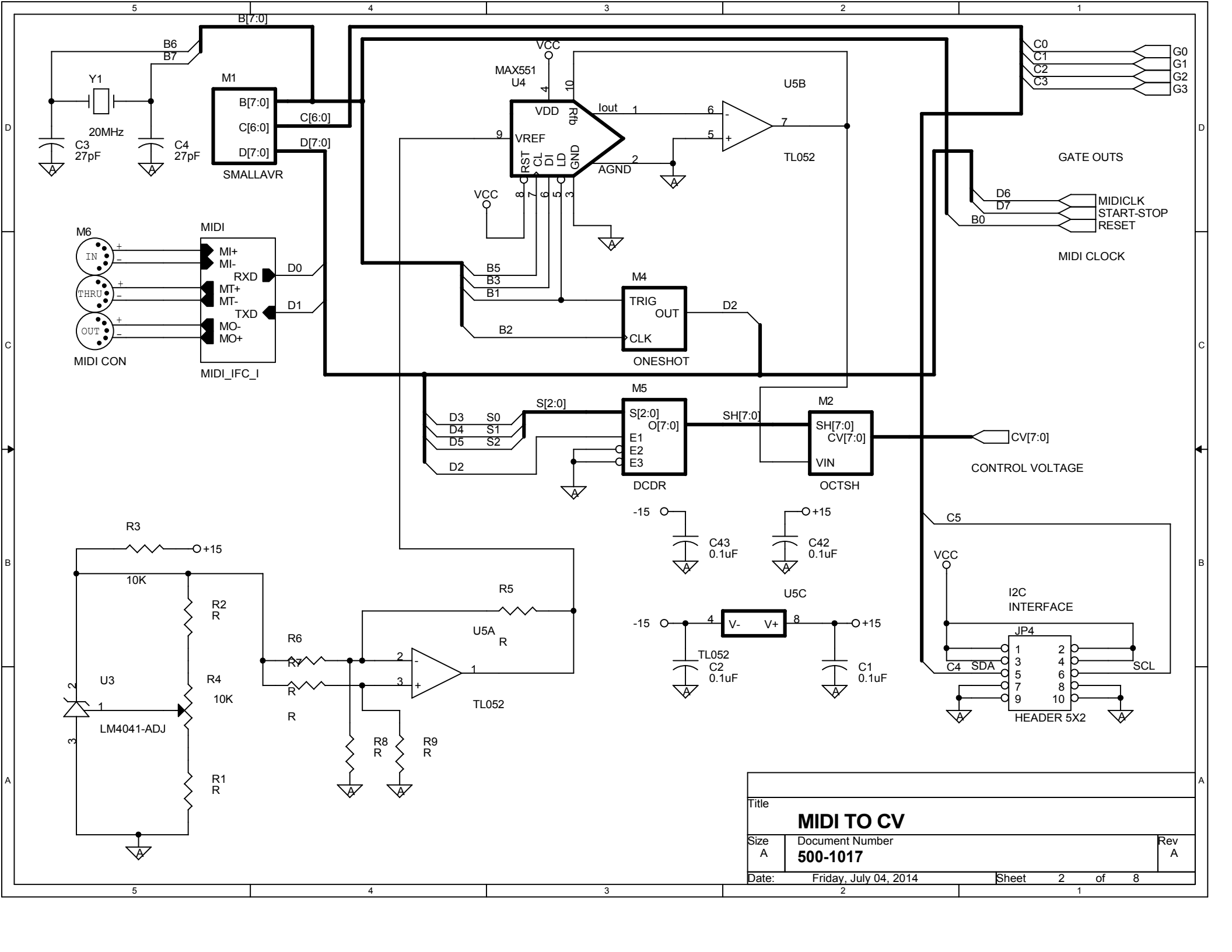

Title		
MIDI TO CV		
Size	Document Number	Rev
A	500-1017	A
Date:	Friday, July 04, 2014	Sheet 2 of 8

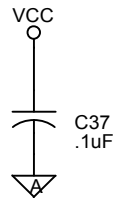
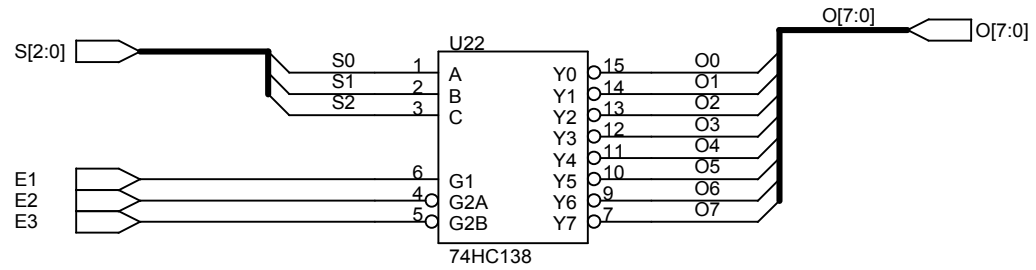

Title		
<Title>		
Size	Document Number	Rev
A	<Doc>	<RevCode>
Date:	Thursday, July 03, 2014	Sheet 3 of 8

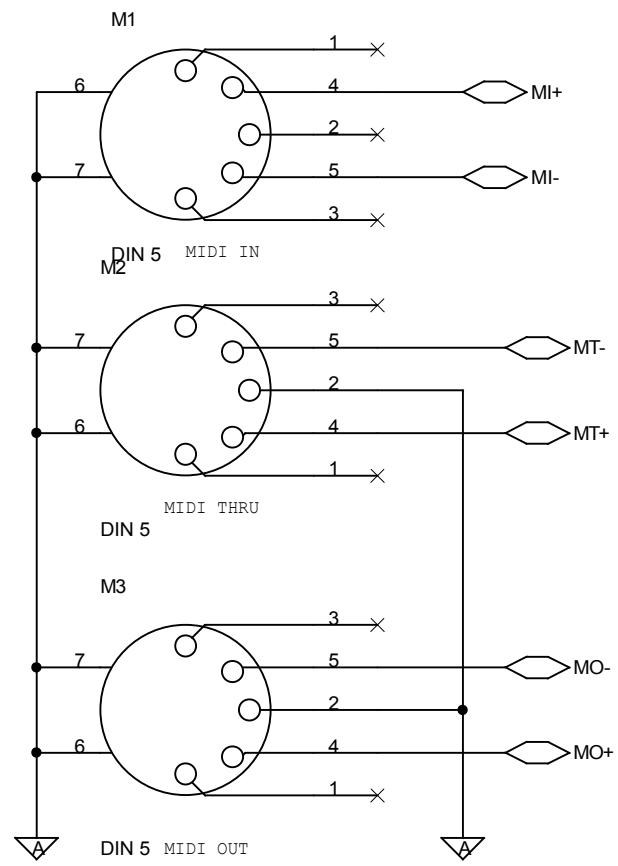

Title		
MIDI CONNECTORS		
Size	Document Number	Rev
A	<Doc>	<RevCode>
Date:	Thursday, July 03, 2014	Sheet 4 of 8

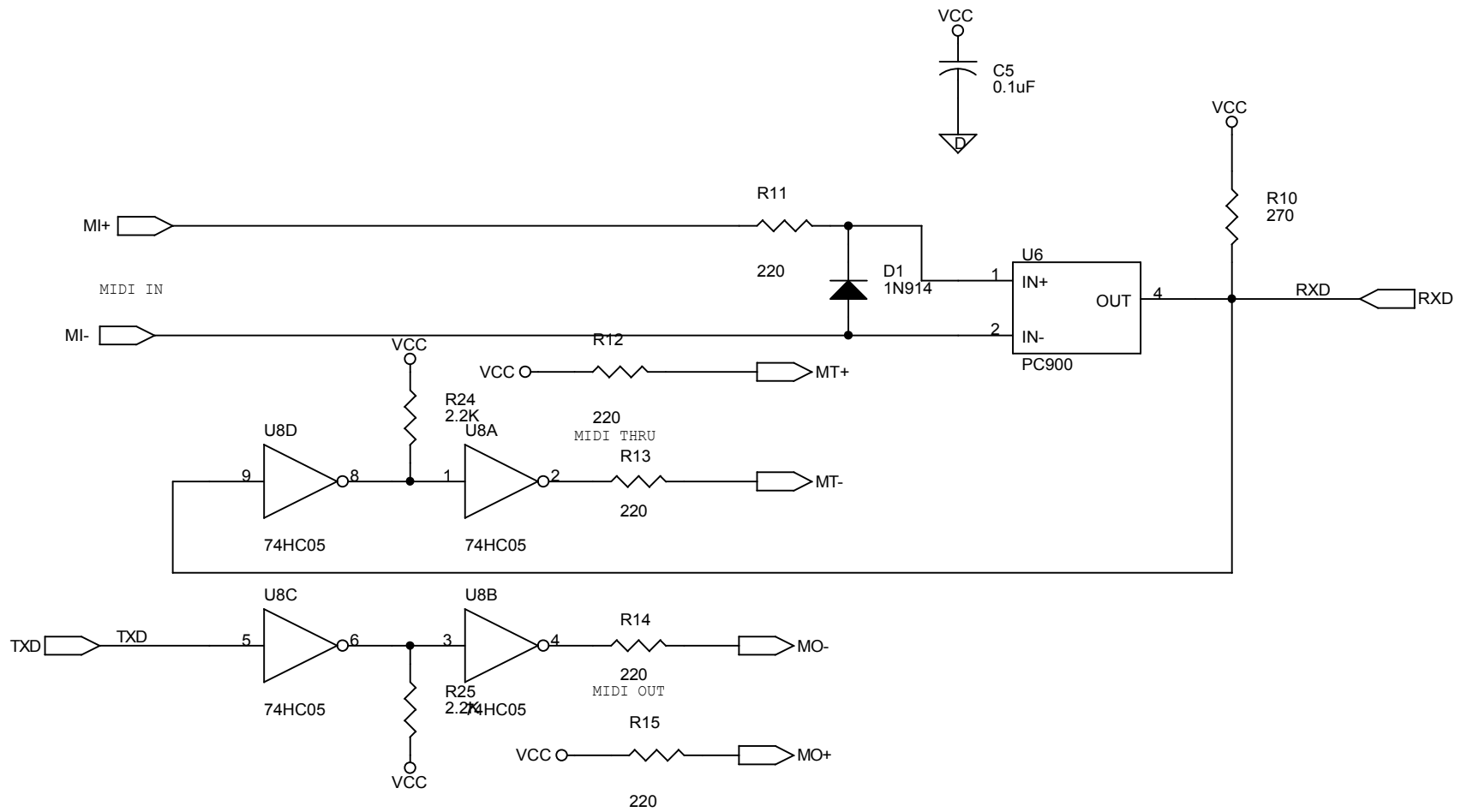

Title		
MIDI		
Size	Document Number	Rev
	<Doc>	A
Date:	Friday, July 04, 2014	Sheet 5 of 8

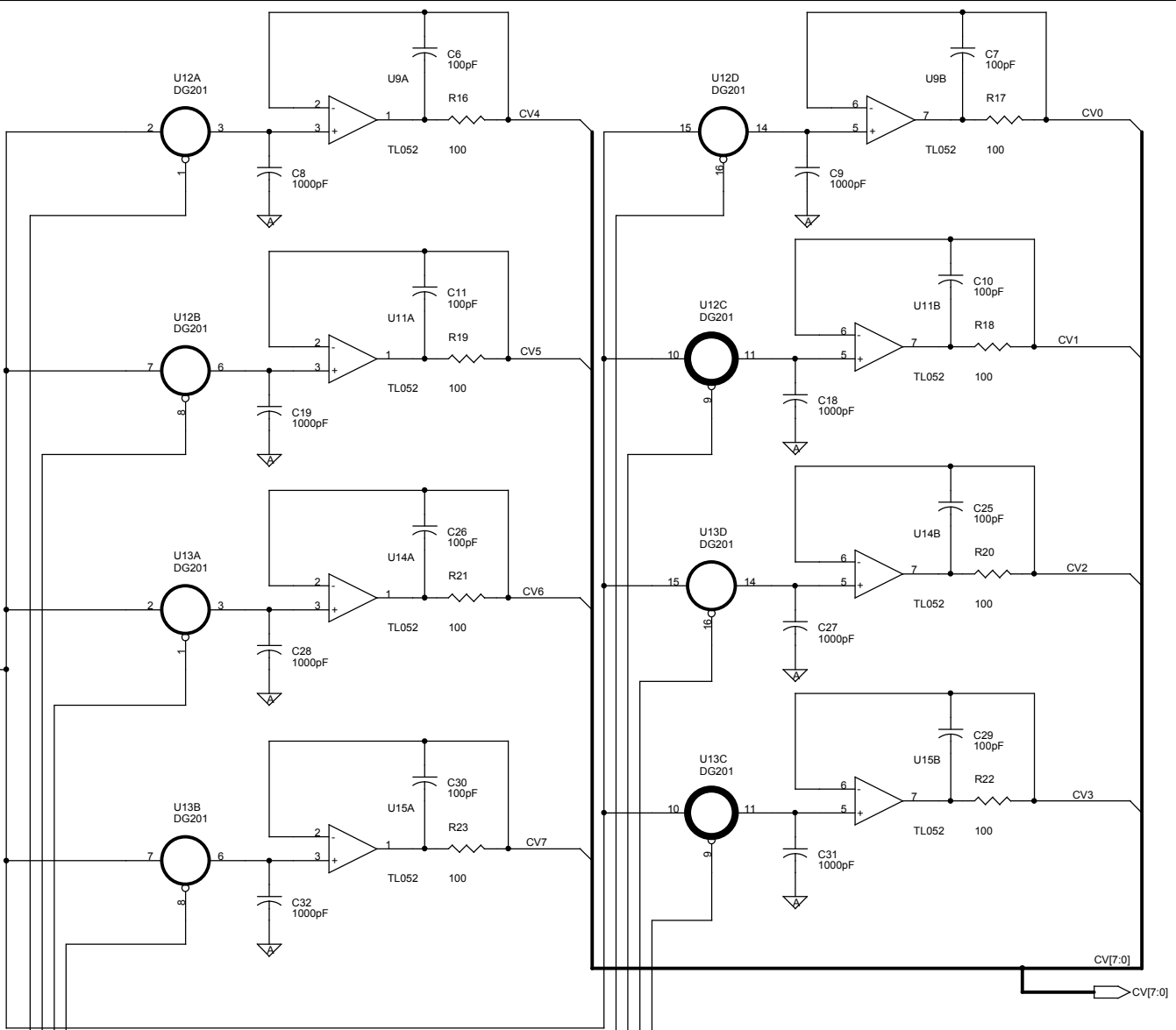
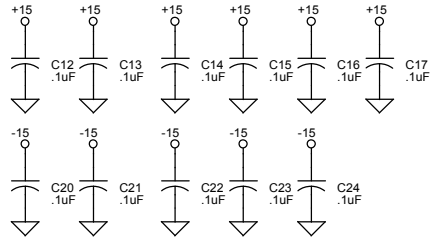
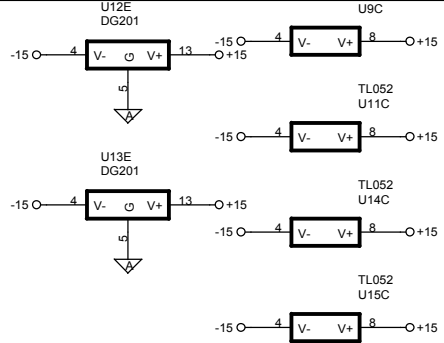

VIN

SH[7:0]

- SH0
- SH1
- SH2
- SH3
- SH4
- SH5
- SH6
- SH7

Title		
OCTAL S/H		
Size	Document Number	Rev
	<Doc>	A
Date:	Friday, July 04, 2014	Sheet 6 of 8

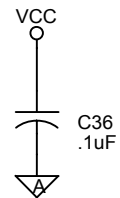
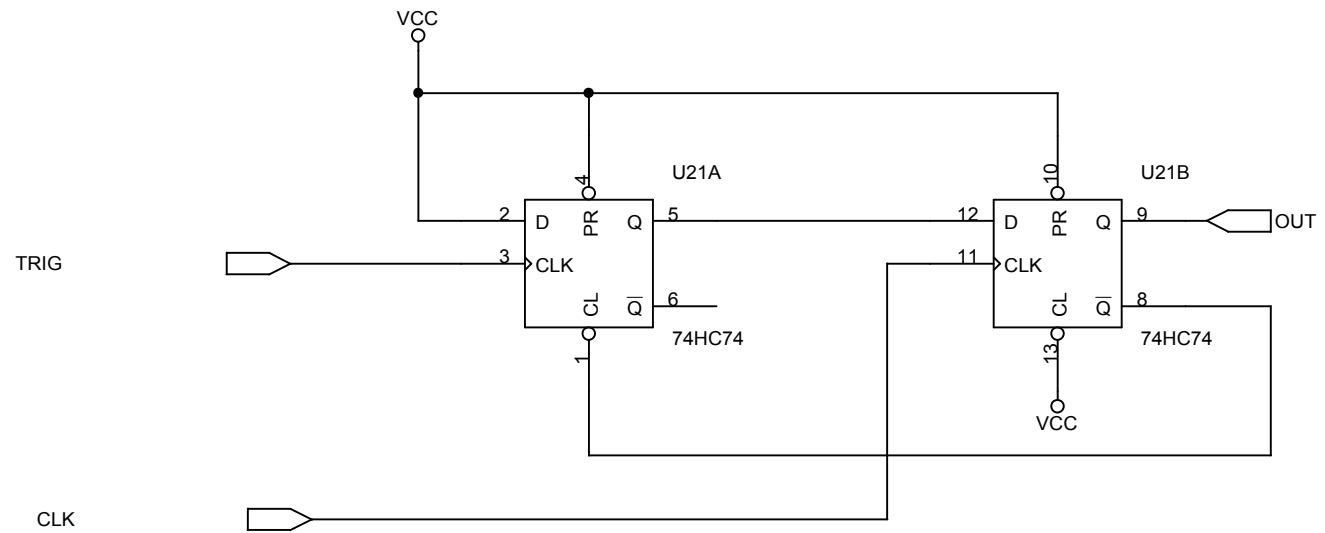

Title		
ONE SHOT		
Size	Document Number	Rev
A	<Doc>	<RevCode>
Date:	Thursday, July 03, 2014	Sheet 7 of 8

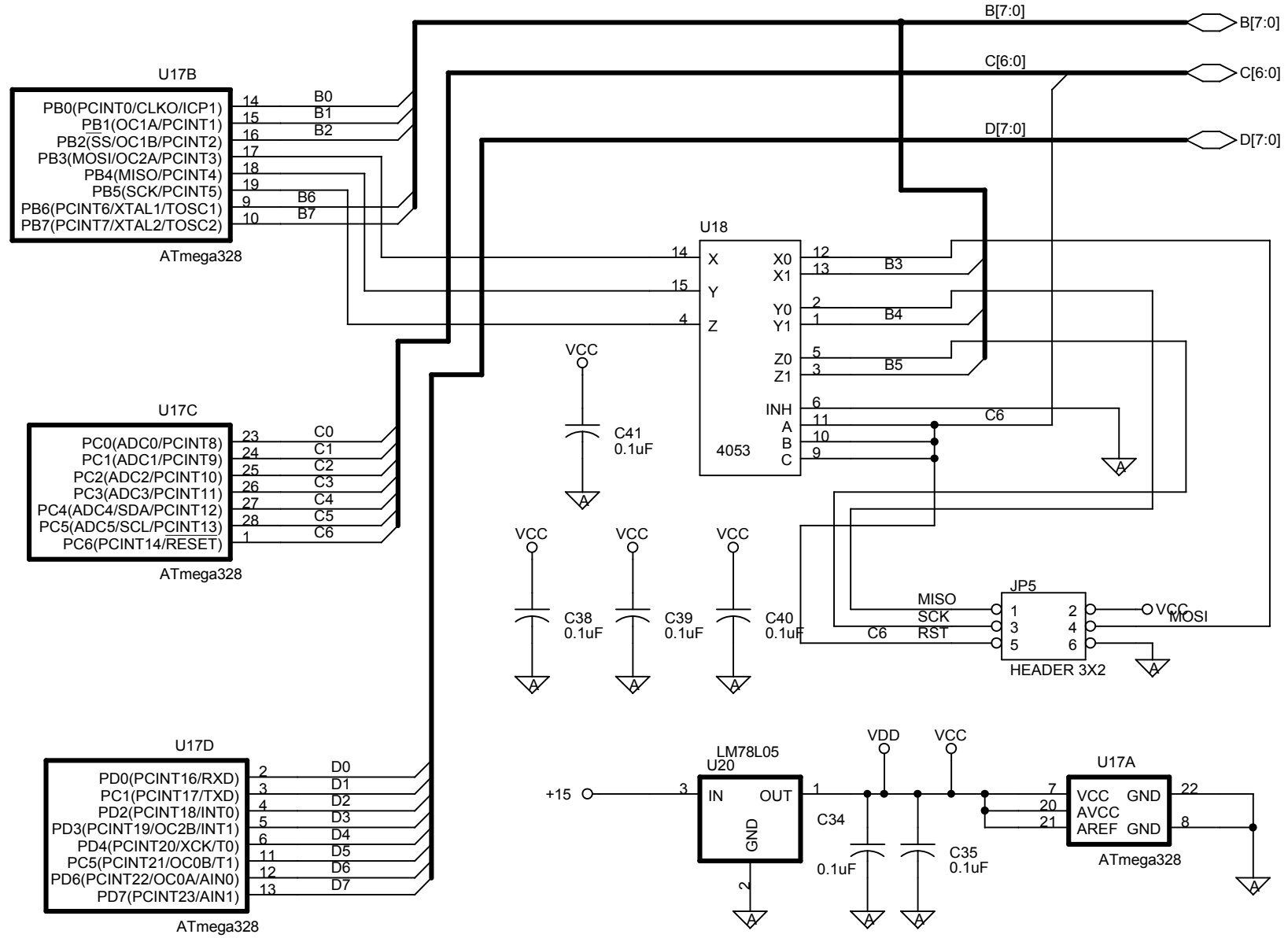

Title		
ATmega328 CPU		
Size	Document Number	Rev
A	<Doc>	B
Date:	Friday, July 04, 2014	Sheet 8 of 8